

## Reliability and Test Condition

Item	Performance	Test Condition
Operating Temperature	-55°C ~ +155°C (Including self - temperature rise)	
Storage temperature and Humidity range	1. -10~+40°C, 50~60%RH (Product with taping) 2. -55~+155°C (on board)	
<b>Electrical Performance Test</b>		
Inductance	Refer to standard electrical characteristics list.	HP4294A, CH3302, CH1320, CH1320S LCR Meter.
RDC		CH502AC, BK2840 Micro-Ohm Meter
Saturation Current (Isat1)	Approximately $\Delta$ L30%	Saturation DC Current (Isat) will cause L0 to drop $\Delta$ L(%)
Heat Rated Current (Irms)	Approximately $\Delta$ T40°C	Heat Rated Current (Irms) will cause the coil temperature rise $\Delta$ T(°C). 1. Applied the allowed DC current 2. Temperature measured by digital surface thermometer
<b>Reliability Test</b>		
High Temperature Exposure(Storage) AEC-Q200	Appearance : No damage. Inductance : within $\pm$ 10% of initial value Q : Shall not exceed the specification value. RDC : within $\pm$ 15% of initial value and shall not exceed the specification value.	Preconditioning: Run through IR reflow for 3 times. ( IPC/JEDEC J-STD-020E Classification Reflow Profiles) Temperature : 155 $\pm$ 2°C Duration : 1000hrs Min. Measured at room temperature after placing for 24 $\pm$ 2 hrs
Temperature Cycling AEC-Q200		Preconditioning: Run through IR reflow for 3 times. ( IPC/JEDEC J-STD-020E Classification Reflow Profiles) Condition for 1 cycle Step1 : -55 $\pm$ 2°C 30min Min. Step2 : 155 $\pm$ 2°C transition time 1min MAX. Step3 : 155 $\pm$ 2°C 30min Min. Step4 : Low temp. transition time 1min MAX. Number of cycles : 1000 Measured at room temperature after placing for 24 $\pm$ 2 hrs
Biased Humidity (AEC-Q200)		Preconditioning: Run through IR reflow for 3 times. ( IPC/JEDEC J-STD-020E Classification Reflow Profiles) Humidity : 85 $\pm$ 3% R.H, Temperature : 85°C $\pm$ 2°C Duration : 1000hrs Min with 100% rated current. Measured at room temperature after placing for 24 $\pm$ 2 hrs
High Temperature Operational Life (AEC-Q200)		Preconditioning: Run through IR reflow for 3 times. ( IPC/JEDEC J-STD-020E Classification Reflow Profiles) Temperature : 155 $\pm$ 2°C (Inductor) Duration : 1000hrs Min. with 100% rated current. Measured at room temperature after placing for 24 $\pm$ 2 hrs
External Visual		Appearance : No damage
Physical Dimension	According to the product specification size measurement	According to the product specification size measurement

## Reliability and Test Condition

Item	Performance	Test Condition															
<b>Reliability Test</b>																	
Resistance to Solvents	Appearance : No damage.	Add aqueous wash chemical - OKEM clean or equivalent.															
Mechanical Shock	Appearance : No damage. Inductance : within±10% of initial value Q : Shall not exceed the specification value. RDC : within ±15% of initial value and shall not exceed the specification value.	Preconditioning: Run through IR reflow for 3 times. ( IPC/JEDEC J-STD-020E Classification Reflow Profiles) Test condition <table border="1"> <thead> <tr> <th>Type</th> <th>Peak value (g's)</th> <th>Normal duration (D) (ms)</th> <th>Wave form</th> <th>Velocity change (Vi)ft/sec</th> </tr> </thead> <tbody> <tr> <td>SMD</td> <td>100</td> <td>6</td> <td>Half-sine</td> <td>12.3</td> </tr> <tr> <td>Lead</td> <td>100</td> <td>6</td> <td>Half-sine</td> <td>12.3</td> </tr> </tbody> </table> shocks in each direction along 3 perpendicular axes.	Type	Peak value (g's)	Normal duration (D) (ms)	Wave form	Velocity change (Vi)ft/sec	SMD	100	6	Half-sine	12.3	Lead	100	6	Half-sine	12.3
Type	Peak value (g's)	Normal duration (D) (ms)	Wave form	Velocity change (Vi)ft/sec													
SMD	100	6	Half-sine	12.3													
Lead	100	6	Half-sine	12.3													
Vibration	Appearance : No damage. Inductance : within±10% of initial value Q : Shall not exceed the specification value. RDC : within ±15% of initial value and shall not exceed the specification value.	IPC/JEDEC J-STD-020E Classification Reflow Profiles Oscillation Frequency: 10Hz~2KHz~10Hz for 20 minute Equipment : Vibration checker Total Amplitude: 5g Testing Time : 12 hours (20 minutes, 12 cycles each of 3 orientations) °															
Resistance to Soldering Heat		Test condition:(MIL-STD-202 Condition B) <table border="1"> <thead> <tr> <th>Temperature(°C)</th> <th>Time(s)</th> <th>Temperature ramp/immersion and emersion rate</th> <th>Number of heat cycles</th> </tr> </thead> <tbody> <tr> <td>260±5 (solder temp)</td> <td>10±1</td> <td>25mm/s ±6 mm/s</td> <td>1</td> </tr> </tbody> </table> Depth: completely cover the termination	Temperature(°C)	Time(s)	Temperature ramp/immersion and emersion rate	Number of heat cycles	260±5 (solder temp)	10±1	25mm/s ±6 mm/s	1							
Temperature(°C)		Time(s)	Temperature ramp/immersion and emersion rate	Number of heat cycles													
260±5 (solder temp)	10±1	25mm/s ±6 mm/s	1														
Thermal shock (AEC-Q200)	Preconditioning: Run through IR reflow for 3 times. ( IPC/JEDEC J-STD-020E Classification Reflow Profiles) Condition for 1 cycle Step1 : -55±2°C 15±1min Step2 : 155±2°C within 20Sec. Step3 : 155±2°C 15±1min Number of cycles : 300 Measured at room fempraturc after placing for 24±2 hrs																
ESD	Appearance : No damage.																

## Reliability and Test Condition

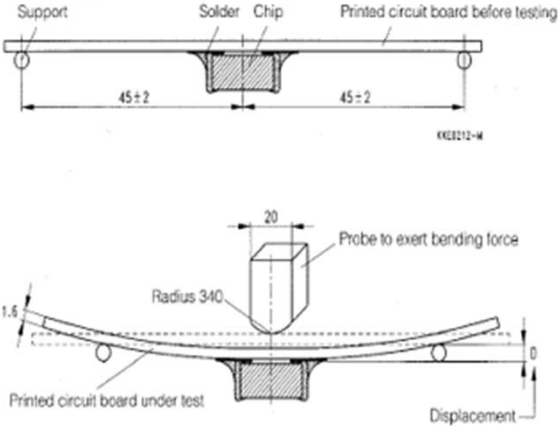
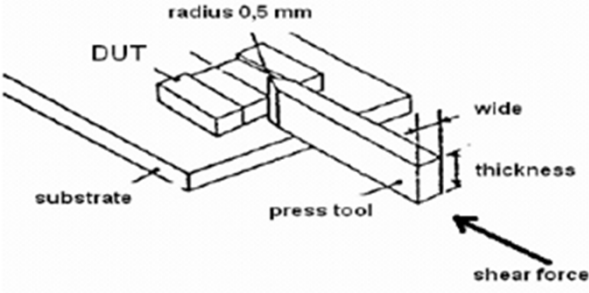
Item	Performance	Test Condition
<b>Reliability Test</b>		
Solderability	More than 95% of the terminal electrode should be covered with solder ◦	a. Method B, 4 hrs @155°C dry heat @235°C±5°C Test time:5 +0/-0.5 seconds b. Method D category 3 (steam aging 8 hours ± 15 min)@ 260°C±5°C Test time: 30 +0/-0.5 seconds
Electrical Characterization	Refer Specification for Approval	Summary to show Min, Max, Mean and Standard deviation
Flammability	Electrical Test not required	V-0 or V-1 are acceptable.
Board Flex	Appearance : No damage	<p>Preconditioning: Run through IR reflow for 3 times.            ( IPC/JEDEC J-STD-020E Classification Reflow Profiles)            Place the 100mm X 40mm board into a fixture similar to the one shown in below Figure with the component facing down.</p> <p>The apparatus shall consist of mechanical means to apply a force which will bend the board (D) x = 2 mm minimum.            The duration of the applied forces shall be 60 (+ 5) sec.</p> 
Terminal Strength (SMD)	Appearance : No damage	<p>Preconditioning: Run through IR reflow for 3 times.            ( IPC/JEDEC J-STD-020E Classification Reflow Profiles)            With the component mounted on a PCB with the device to be tested, apply a 17.7 N (1.8 Kg) force to the side of a device being tested. This force shall be applied for 60 +1 seconds.            Also the force shall be applied gradually as not to apply a shock to the component being tested.</p> 
<p>Note : When there are questions concerning measurement result measurement shall be made after 48 ± 2 hours Of recovery under the standard condition.</p>		

## Reliability and Test Condition

Item	Performance	Test Condition
<b>Soldering and Mounting</b>		
Soldering	Mildly activated rosin fluxes are preferred. JANTEK terminations are suitable for all wave and re-flow soldering systems. If hand soldering cannot be avoided, the preferred technique is the utilization of hot air soldering tools.	
IR Soldering Reflow:	Recommended temperature profiles for lead free re-flow soldering in Figure 1. Table 1.1&1.2 (J-STD-020E)	
Iron Reflow:	<p>Products attachment with a soldering iron is discouraged due to the inherent process control limitations. In the event that a soldering iron must be employed the following precautions are recommended. (Fig. 2)</p> <p>Note :</p> <ul style="list-style-type: none"> <li>• Preheat circuit and products to 150°C</li> <li>• Never contact the ceramic with the iron tip</li> <li>• Use a 20 watt soldering iron with tip diameter of 1.0mm</li> <li>• 355°C tip temperature (max)</li> <li>• 1.0mm tip diameter (max)</li> <li>• Limit soldering time to 4~5 sec</li> </ul>	

**Fig.1 IR Soldering Reflow**

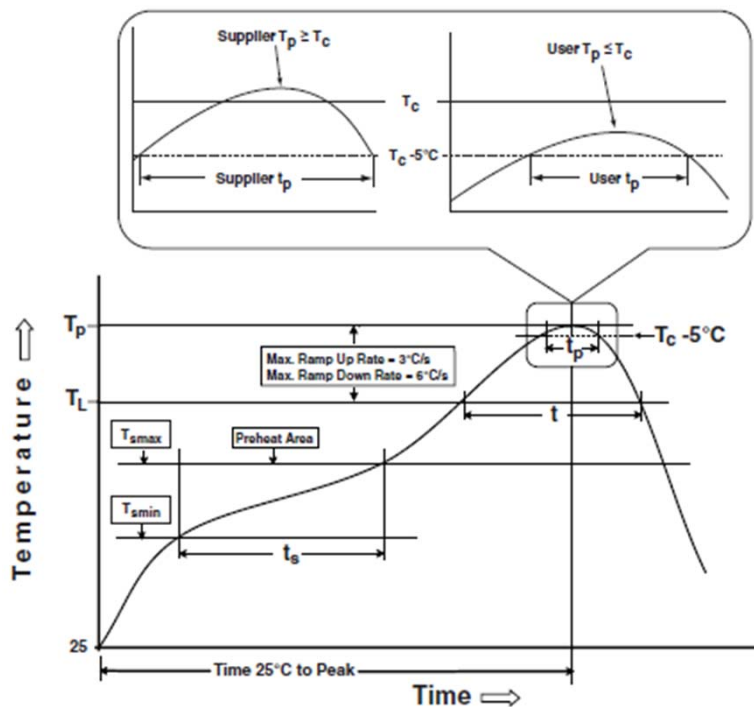

Reflow times: 3 times max

**Fig.2 Iron soldering temperature profiles**

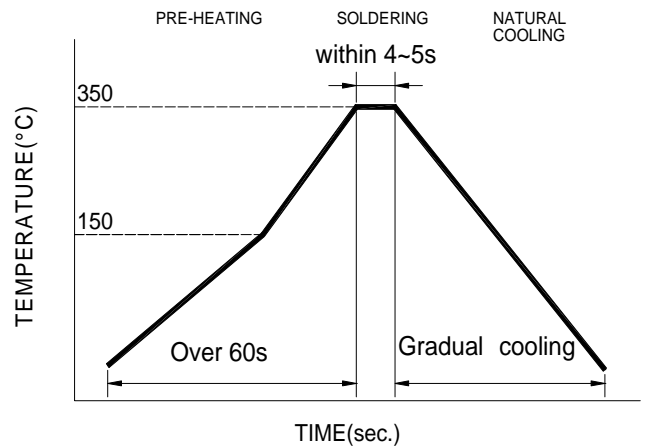

Iron Soldering times : 1 times max  
Soldering iron Method :  $350 \pm 5^\circ\text{C}$  max

**Table (1.1): Reflow Profiles**

Profile Type:	Pb-Free Assembly
Preheat	
-Temperature Min( $T_{smin}$ )	150°C
-Temperature Max( $T_{smax}$ )	200°C
-Time( $t_s$ )from( $T_{smin}$ to $T_{smax}$ )	60-120seconds
Ramp-up rate( $T_L$ to $T_p$ )	3°C/second max.
Liquidus temperature( $T_L$ )	217°C
Time( $t_L$ )maintained above $T_L$	60-150 seconds
Classification temperature( $T_c$ )	See Table (1.2)
Time( $t_p$ ) at $T_c - 5^\circ\text{C}$ ( $T_p$ should be equal to or less than $T_c$ .)	* < 30 seconds
Ramp-down rate( $T_p$ to $T_L$ )	6°C /second max.
Time 25°C to peak temperature	8 minutes max.

**T<sub>p</sub>**: maximum peak package body temperature, **T<sub>c</sub>**: the classification temperature.

For user (customer) **T<sub>p</sub>** should be equal to or less than **T<sub>c</sub>**.

\* Tolerance for peak profile temperature ( $T_p$ ) is defined as a supplier minimum and a user maximum.

**Table (1.2) Package Thickness/Volume and Classification Temperature (T<sub>c</sub>)**

	Package Thickness	Volume mm <sup>3</sup> <350	Volume mm <sup>3</sup> 350-2000	Volume mm <sup>3</sup> >2000
PB-Free Assembly	<1.6mm	260°C	260°C	260°C
	1.6-2.5mm	260°C	250°C	245°C
	≥2.5mm	250°C	245°C	245°C

Reflow is referred to standard IPC/JEDEC J-STD-020E

## Notes:

- (1) When there are questions concerning measurement result : measurement shall be made after  $48 \pm 2$  hours of recovery under the standard condition ◦
- (2) This power choke coil itself does not have any protective function in abnormal condition such as overload, short-circuit and open-circuit conditions, etc. Therefore, it shall be confirmed as the end product that there is no risk of smoking, fire, dielectric withstand voltage, insulation resistance, etc. in abnormal conditions to provide protective devices and/or protection circuit in the end product ◦
- (3) When this power choke coil was used in a similar or new product to the original one, sometimes it might not be able to satisfy the specifications due to different condition of use ◦
- (4) Dielectric withstanding test with higher voltage than specific value will damage insulating material and shorten its life ◦
- (5) This power choke coil must not be used in wet condition by water, coffee or any liquid because insulation strength becomes very low in this condition ◦
- (6) Please consult our company to confirm the reliability of the process required to wash or use or exposure to a chemical solvent used in this product. PCB washing tested to MIL-STD-202 Method ◦ and dry it off immediately ◦
- (7) The rated current as listed is either the saturation current or the heating current depending on which value is lower ◦
- (8) If this power choke is dipped in the cleaning agent, such as toluene, xylene, ketone, and ether system, there is a possibility that the performance decreases greatly, and marking disappearanc ◦
- (9) The high power ultrasonic washing may damage the choke body ◦